

## TYPE "LWZ-2" CLUTCH

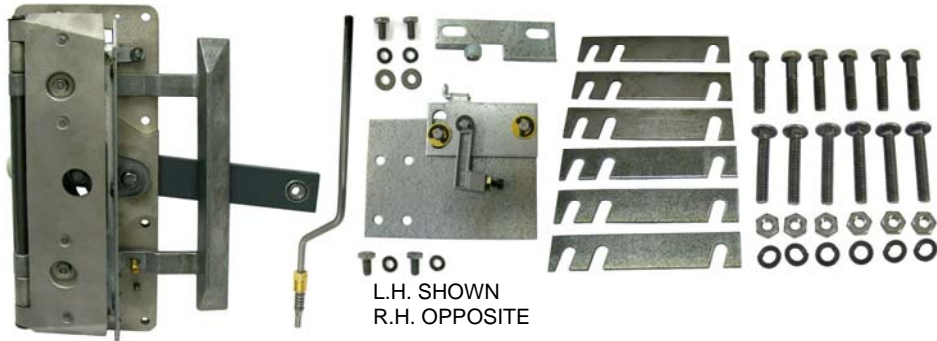

## TYPE "LWZ-2-LOW" CLUTCH



Door Opening					Link Size	LWZ-2 Part Number	LWZ-2-LOW Part Number
S/S	2/SP	C/P	2SP/CP	3/SP			
22-29 40-44	40-44	80-83			10"	CLU9-0001L/R	CLU9-0013L/R
30-34	27-34	34-49	50-59	35-39	6"	CLU9-0002L/R	CLU9-0014L/R
35-39	35-39	50-59 68-74	68-74	40-44	8"	CLU9-0003L/R	CLU9-0015L/R
45-48	45-52				12"	CLU9-0004L/R	CLU9-0016L/R
	24-26	24-33	32-49	30-34	5 1/4"	CLU9-0005L/R	CLU9-0017L/R
	53-56			55-59	12"	CLU9-0006L/R	CLU9-0018L/R
	57-64			60-64	14"	CLU9-0007L/R	CLU9-0019L/R
	65-72			65-69	16"	CLU9-0008L/R	CLU9-0020L/R
		60-67	60-67		7"	CLU9-0009L/R	CLU9-0021L/R
		75-79	75-79	45-49	9"	CLU9-0010L/R	CLU9-0022L/R
			80-83		10"	CLU9-0011L/R	CLU9-0023L/R
				50-54	11"	CLU9-0012L/R	CLU9-0024L/R

### TYPE "LWZ-2-LRC STD" CLUTCH

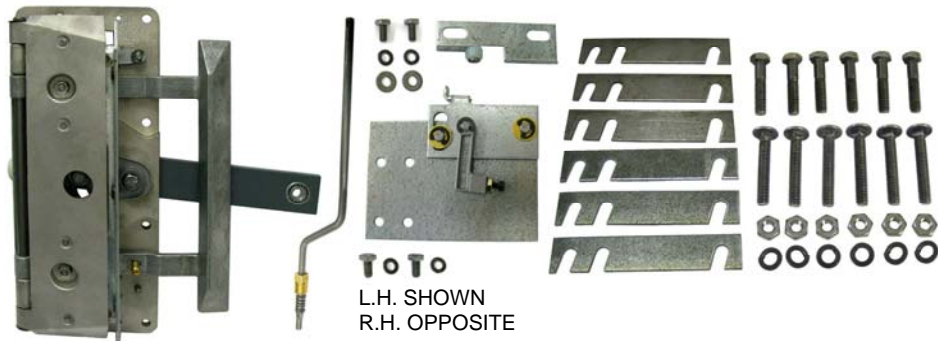

### TYPE "LWZ-2-LRC LOW" CLUTCH

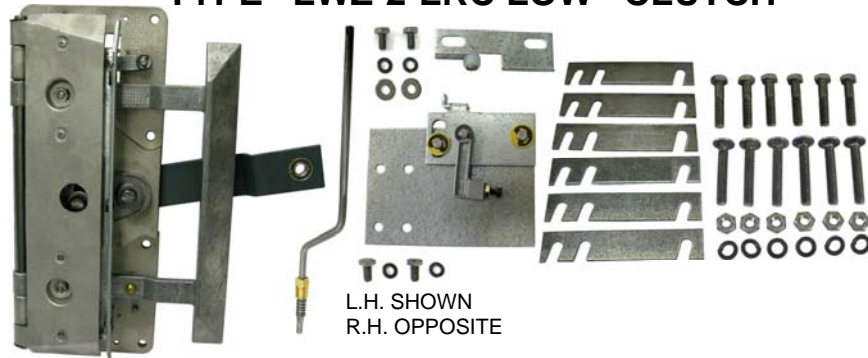

Door Opening					Link Size	LWZ-2-LRC STD Part Number	LWZ-2-LRC LOW Part Number
S/S	2/SP	C/P	2SP/CP	3/SP			
22-29 40-44	40-44	80-83			10"	CLU9-0193L/R	CLU9-0205L/R
30-34	27-34	34-49	50-59	35-39	6"	CLU9-0194L/R	CLU9-0206L/R
35-39	35-39	50-59 68-74	68-74	40-44	8"	CLU9-0195L/R	CLU9-0207L/R
45-48	45-52				12"	CLU9-0196L/R	CLU9-0208L/R
	24-26	24-33	32-49	30-34	5 1/4"	CLU9-0197L/R	CLU9-0209L/R
	53-56			55-59	12"	CLU9-0198L/R	CLU9-0210L/R
	57-64			60-64	14"	CLU9-0199L/R	CLU9-0211L/R
	65-72			65-69	16"	CLU9-0200L/R	CLU9-0212L/R
		60-67	60-67		7"	CLU9-0201L/R	CLU9-0213L/R
		75-79	75-79	45-49	9"	CLU9-0202L/R	CLU9-0214L/R
			80-83		10"	CLU9-0203L/R	CLU9-0215L/R
				50-54	11"	CLU9-0204L/R	CLU9-0216L/R

## TYPE “LWZ-2-HA, LWZ-2-HA-LOW, LWZ-2-HA-LRC STD & LOW” CLUTCH “CLU9”

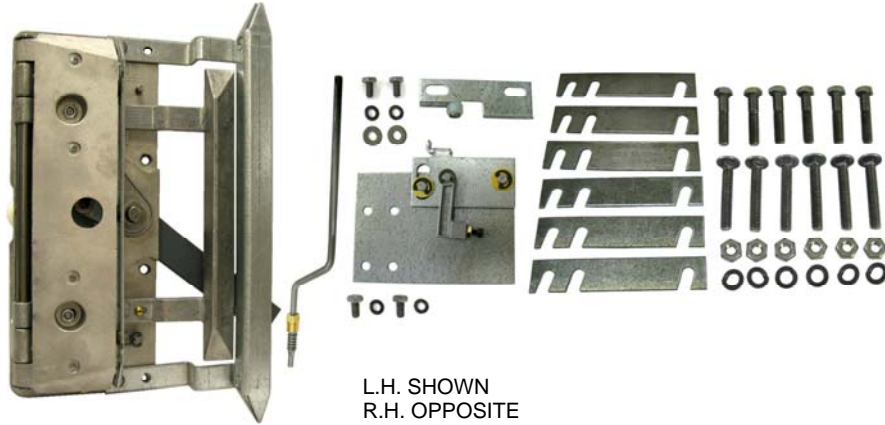

**WORK SHEET REQUIRED!**

Door Opening			Link Size	LWZ-2-HA Part Number	LWZ-2-HA-LOW Part Number	LWZ-2-HA-LRC STD Part Number	LWZ-2-HA-LRC LOW Part Number
S/S	2/SP	C/P					
25-34	27-34	34-49	6"	CLU9-0140L/R	CLU9-0148L/R	CLU9-0156L/R	CLU9-0164L/R
35-42	35-39	50-59	8"	CLU9-0141L/R	CLU9-0149L/R	CLU9-0157L/R	CLU9-0165L/R
	24-26	30-33	5 1/4"	CLU9-0142L/R	CLU9-0150L/R	CLU9-0158L/R	CLU9-0166L/R
	40-44		10"	CLU9-0143L/R	CLU9-0151L/R	CLU9-0159L/R	CLU9-0167L/R
	45-52		12"	CLU9-0144L/R	CLU9-0152L/R	CLU9-0160L/R	CLU9-0168L/R
	53-56		12"	CLU9-0145L/R	CLU9-0153L/R	CLU9-0161L/R	CLU9-0169L/R
	57-64		14"	CLU9-0146L/R	CLU9-0154L/R	CLU9-0162L/R	CLU9-0170L/R
	65-72		16"	CLU9-0147L/R	CLU9-0155L/R	CLU9-0163L/R	CLU9-0171L/R

## TYPE "LWZ-2" CLUTCHES

LWZ-2 & LWZ-2-LRC STD CLUTCH LINK

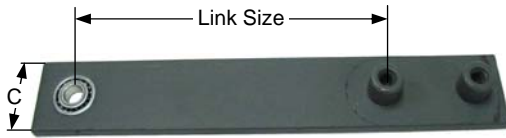

LWZ-2-LOW & LWZ-2-LRC LOW CLUTCH LINK

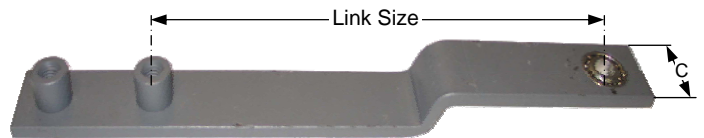

S/S D.O.	2/SP D.O.	3/SP D.O.	C/P D.O.	2SP/CP D.O.	Link Size	"C" Width	LWZ-2 & LWZ-2-LRC STD Part Number	LWZ-2-LOW & LWZ-2-LRC LOW Part Number
	24-26	30-34	24-33	32-49	5 1/4"	1 1/4"	<b>CLU9-0083N</b>	<b>CLU9-0063N</b>
30-34	27-34	35-39	34-49	50-59	6"		<b>CLU9-0084N</b>	<b>CLU9-0064N</b>
			60-67	60-67	7"		<b>CLU9-0085N</b>	<b>CLU9-0065N</b>
35-39	35-39	40-44	50-59 68-74	68-74	8"		<b>CLU9-0086N</b>	<b>CLU9-0066N</b>
		45-49	75-79	75-79	9"		<b>CLU9-0087N</b>	<b>CLU9-0067N</b>
22-29 40-44	40-44		80-83	80-83	10"	1 1/2"	<b>CLU9-0088N</b>	<b>CLU9-0068N</b>
		50-54			11"		<b>CLU9-0089N</b>	<b>CLU9-0069N</b>
45-48	45-56	55-59			12"		<b>CLU9-0090N</b>	<b>CLU9-0070N</b>
	57-64	60-64			14"		<b>CLU9-0091N</b>	<b>CLU9-0071N</b>
	65-72	65-69			16"		<b>CLU9-0092N</b>	<b>CLU9-0072N</b>

**NOTE:** FOR "HA" JOBS S/S 25-34 D.O. USE 6" CLUTCH LINK & S/S 35-42 D.O. USE 8" CLUTCH LINK.

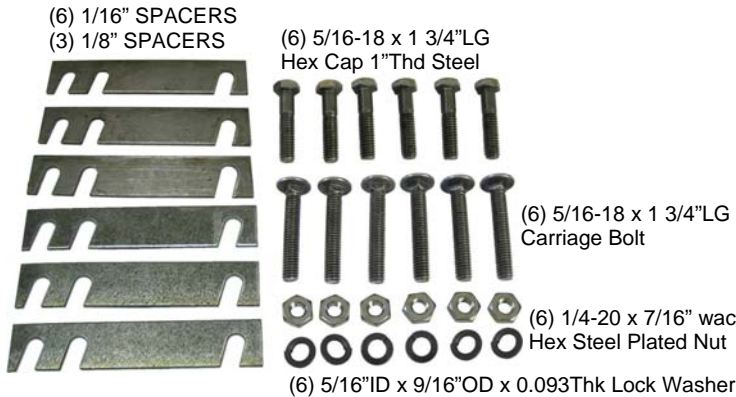

**CLU9-0045N**  
HARDWARE, CLUTCH MOUNTING  
LWZ-2 & LWZ-2-LRC STD CLUTCHES

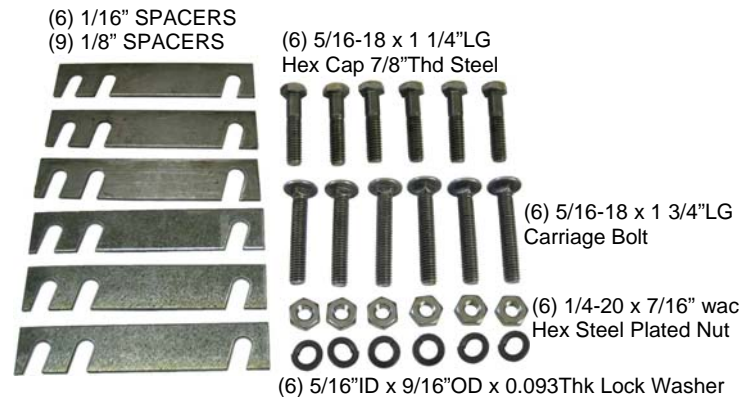

**CLU9-0046N**  
HARDWARE, CLUTCH MOUNTING  
LWZ-2-LOW & LWZ-2-LRC LOW CLUTCHES



**CLU1-0053N**  
SPACER, CLUTCH 1/8" THICK



**CLU1-0054N**  
SPACER, CLUTCH 1/16" THICK

## TYPE "LWZ-2" CLUTCHES



**CLU9-0049L/R** CAM,LWZ-2 STANDARD LOCKING



**CLU9-0047L/R** CAM,LWZ-2 CALIFORNIA LOCKING



**CLU9-0108N** ROD,36" LWZ-2 CLUTCH ZONE LOCKING



**CLU9-0101L/R** GUIDE,LWZ-2 CLUTCH LOCKING

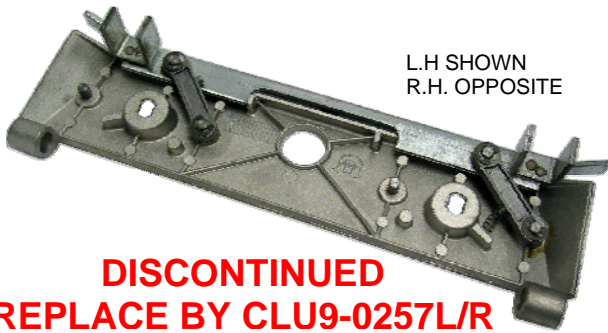

**CLU9-0109L/R** VANE ASSEMBLY,LWZ-2 DOOR OPEN

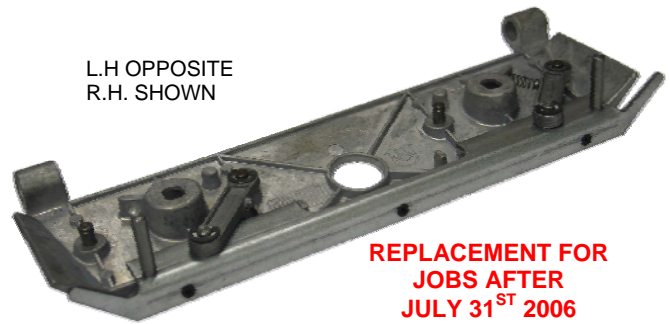

**CLU9-0257L/R** VANE ASSEMBLY,LWZ-2 DOOR OPEN

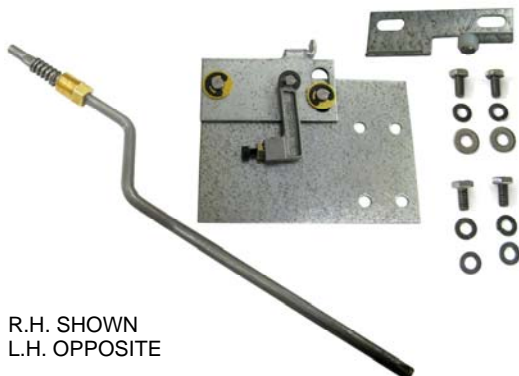

**CLU9-0115L/R**  
LOCKING ASSEMBLY,LWZ-2 CLUTCH 36" ROD  
WITH STANDARD CAM



**CLU9-0114L/R**  
LOCKING ASSEMBLY,LWZ-2 CLUTCH 36" ROD  
WITH CALIFORNIA CAM

## TYPE "LWZ-2" CLUTCHES

### "CLU9"



**CLU9-0104N**  
 SENSING BAR & PIVOT, LWZ-2 ZONE LOCK ASSY



**CLU9-0103N**  
 VANE, LWZ-2 HA CLUTCH REAR ASSEMBLY

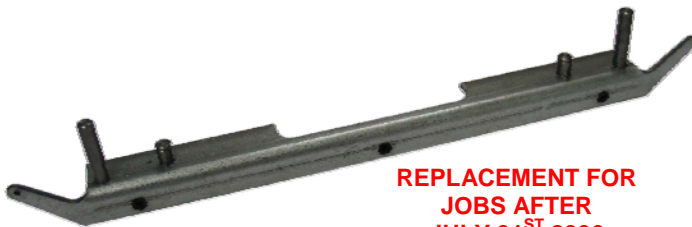

**CLU9-0255N**  
 SENSING BAR & PIVOT, LWZ-2 ZONE LOCK ASSY

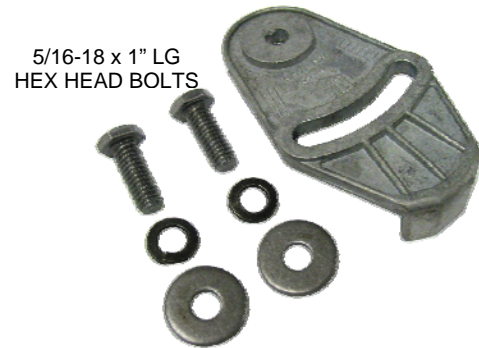

**CLU9-0111N**  
 CAM, LW2 & LWZ-2 CLUTCH ACTUATING

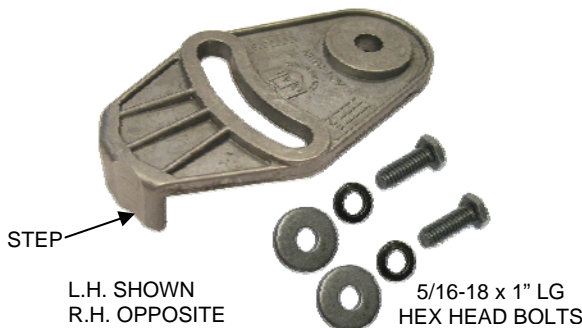

**CLU9-0238L/R**  
 CAM, LW2-LRC & LWZ-2-LRC CLUTCH ACTUATING

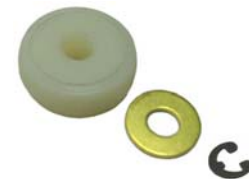

**CLU9-0113N**  
 ROLLER, 1 1/2" DIA LWZ-2 CLUTCH

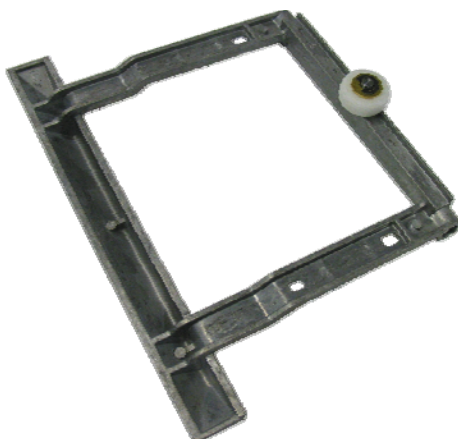

**CLU9-0116N** VANE, LWZ-2 DOOR CLOSE



**CLU9-0117N**  
 ARM, LWZ-2 RETRACTABLE ROLLER ASSEMBLY



**CLU9-0256N** ARM, LWZ-2 RETRACTING ASSEMBLY



## TYPE "LWZ-2" CLUTCHES "CLU9"

LW2 & LWZ-2 CLUTCHES  
(2) SPRING REQUIRED.  
USED ON DOOR CLOSE VANE



**SPG-0019N**  
SPRING, 1 5/8" LG x 3/8" OD.

LWZ-2 CLUTCH  
(1) SPRING REQ'D.  
USED ON DOOR  
OPEN VANE



**SPG-0036N**  
SPRING, 1 1/4" LG x .750 OD

LWZ-2 CLUTCH  
(1) SPRING REQUIRED.  
USED ON SENSING BAR



**SPG-0081N**  
SPRING, 7/8" LG x .240 OD.

LWZ-2 CLUTCH  
USED ON RETRACTABLE ROLLER ARM



**HWBS-0008N**  
BUSHING, NYLINER 1/4 ID x 1/4 HTG

LWZ-2 CLUTCH  
USED ON CLUTCH BASE



**HWBS-0041N**  
BUSHING, NYLINER PLUS 5/8 x 7/16 PLUS

LWZ-2 CLUTCH  
USED ON LOCKING GUIDE ASSEMBLY



**HWBS-0042N**  
BUSHING, NYLINER 5/16 ID x 1/8 HTG

**CLUTCHES FOR “INTERNATIONAL LIFT” STOCK PROGRAM  
 “CLU9”**

**WORK SHEET REQUIRED!**

“LWZ-2 & LWZ-2-LOW”

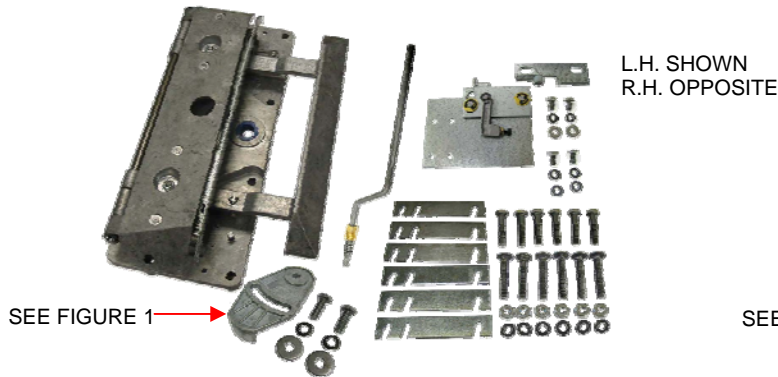

“LWZ-2-LRC STD & LOW”

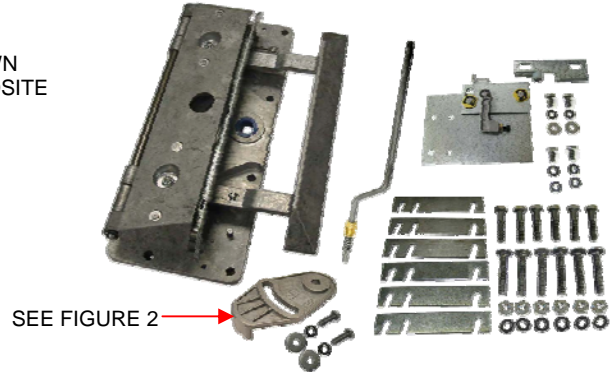

“LWZ-2-HA & LWZ-2-HA-LOW”

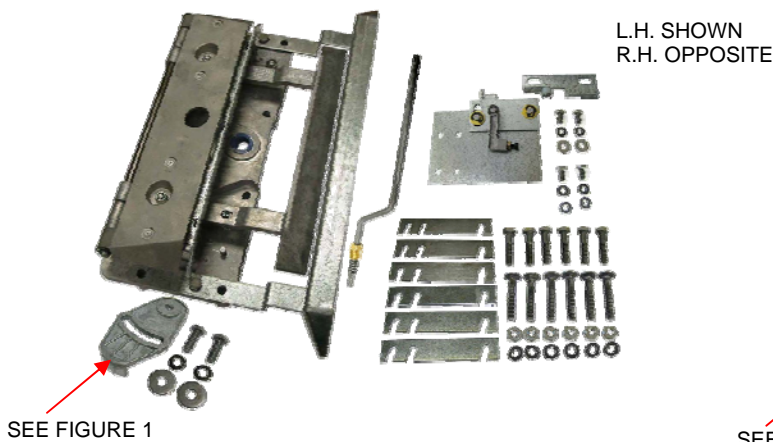

“LWZ-2-HA-LRC STD & LOW”

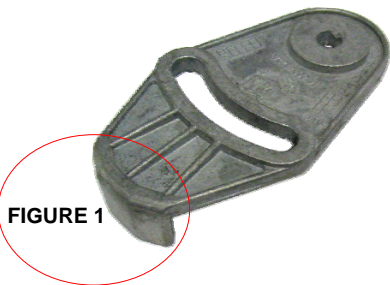
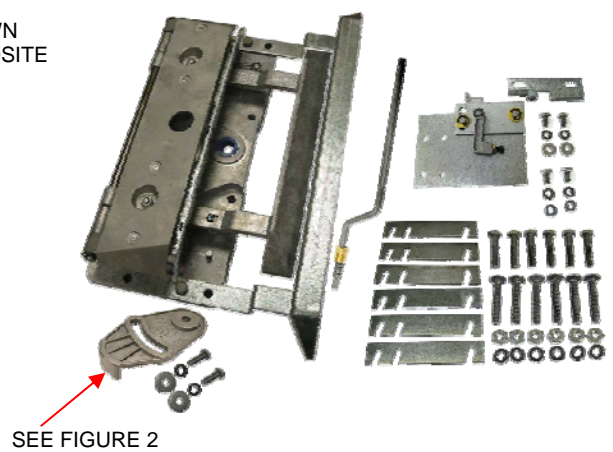

DOOR OPENING					LWZ-2	LWZ-2-LOW	LWZ-2-LRC STD	LWZ-2-LRC LOW
S/S	2/SP	3/SP	2S/CP	C/P	Part Number	Part Number	Part Number	Part Number
22-48	24-72	30-69	30-83	24-83	CLU9-0239L/R	CLU9-0240L/R	CLU9-0241L/R	CLU9-0242L/R
DOOR OPENING					LWZ-2-HA	LWZ-2-HA-LOW	LWZ-2-HA-LRC STD	LWZ-2-HA-LRC LOW
S/S	2/SP	3/SP	2S/CP	C/P	Part Number	Part Number	Part Number	Part Number
22-48	24-72	30-69	30-83	24-83	CLU9-0243L/R	CLU9-0244L/R	CLU9-0245L/R	CLU9-0246L/R